

# AVoIP Decoder DE300

Quick Start Guide V1.0

# Package Contents

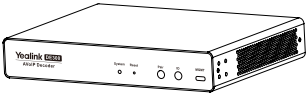

DE300

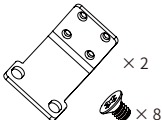

Mounting Ears and Screws

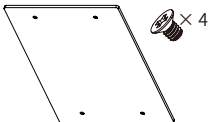

Connection Piece and Screws

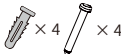

Expansion Nuts and Screws



(12V/2A)  
Power Adapter

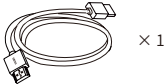

(1.8m,5.9ft)  
HDMI Cable

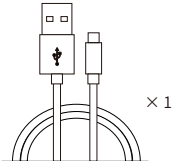

(1m,3.28ft)  
USB 3.0 Type(A-C) Cable

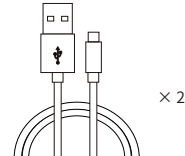

(2.5m,8.2ft)  
USB 3.0 Type(B-A) Cable



Cable Locker



Infrared emitter

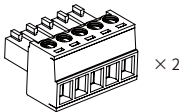

Male Phoenix Connector



Quick Start Guide

 We recommend that you use the accessories provided or approved by Yealink. The use of unapproved third-party accessories may result in poor performance.

- Method 1: Mount on the Rack (19-Inch)
- Single Device Installation

**1** Install the mounting ears on one side of the device.

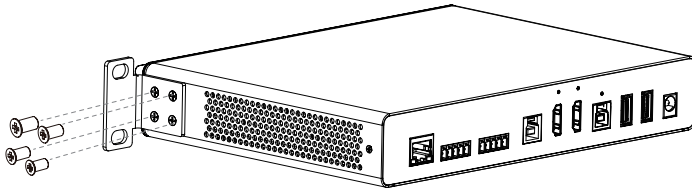

**2** Push the DE300 into the rack and secure it with screws.

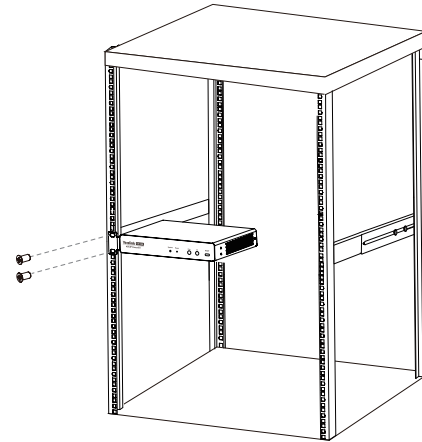

## • Dual Device Installation

- 1 Securely connect the two DE300 devices using screws and connection piece.
- 2 Attach the mounting ears to both the left and right sides of the two DE300 devices .

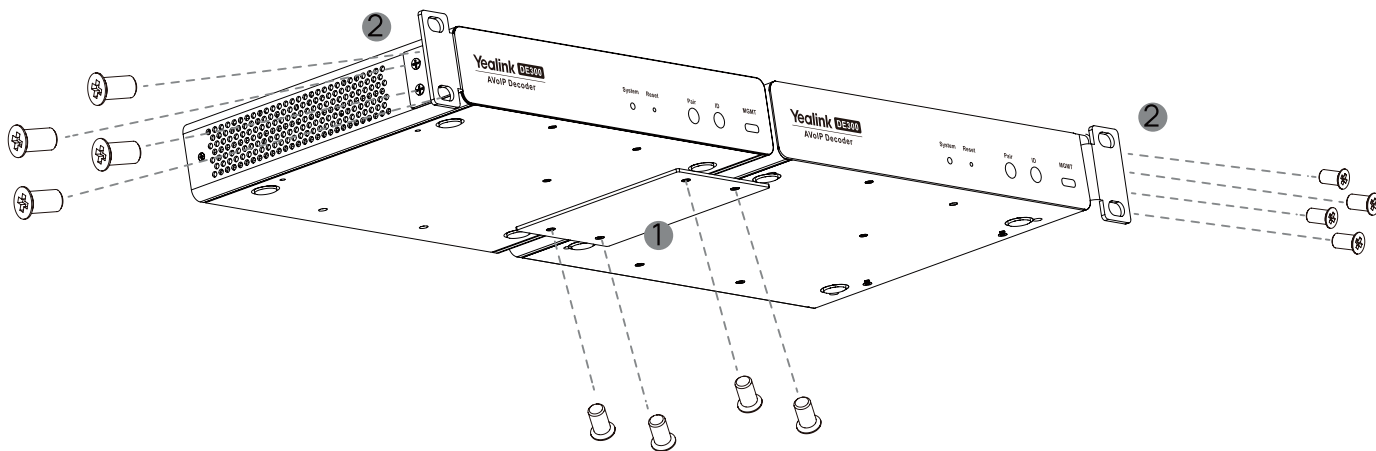

- 3 Push the DE300 into the rack, and then fix it to the rack with screws.

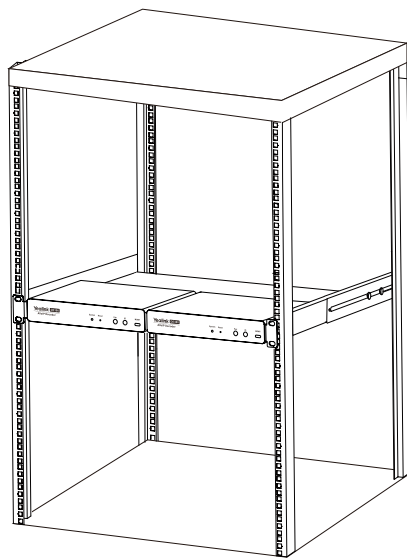

## • Method 2: Under a Table or on a Wall(Using Mount Ears)

- 1 Install the mounting ears on both sides of the DE300.
- 2 Use the mounting ears to mark holes on the mounting surface.
- 3 Drill holes and insert the expansion nuts.
- 4 Fix the DE300 on the mounting surface with the expansion screws.

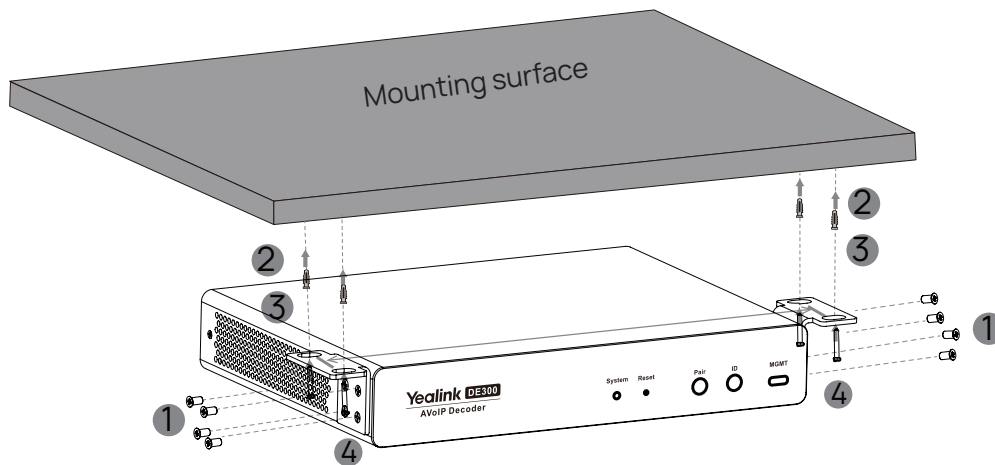

# Hardware Interface Instructions

## Front Panel

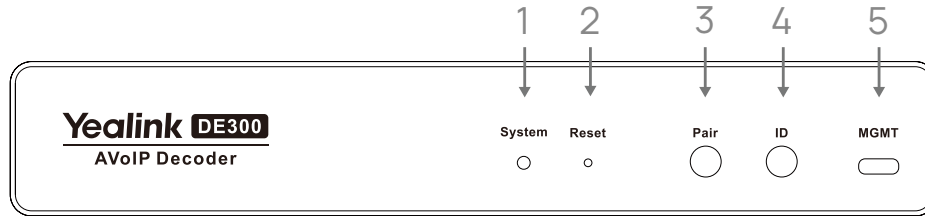

Interface	Description
① System light	See page 10 for the lighting effects.
② Reset	<ul style="list-style-type: none"><li>• After Powering on, hold the button for 5 s to reset DE300 into factory defaults.</li><li>• Power on the device by holding the button, and after powering on, hold the button for 10 s to switch to the backup system.</li></ul>
③ Pair	<p>This button provides two functions:</p> <ul style="list-style-type: none"><li>• Press the button for 3 s to pair encoder.</li><li>• Press the button for 3 s to terminate the pairing.</li></ul> <p>See page 10 for the lighting effects.</p>
④ ID	<p>This button provides two functions:</p> <ul style="list-style-type: none"><li>• Press and release the button to show the host name and IP address.</li><li>• Press the button for 3 s to enable recognition in the software interface.</li></ul>
⑤ MGMT	<p>Connect the computer through this interface to log in to <a href="https://192.168.62.8">https://192.168.62.8</a> to access the device's web interface for management.</p> <p>Note: The default username is admin.</p>

## Rear Panel

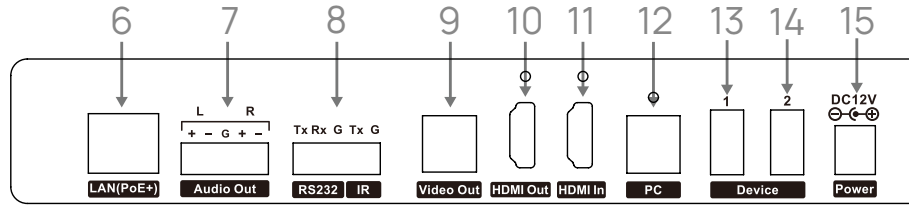

Interface	Description
⑥ LAN	RJ-45 port for video/audio data transmission, device control and management (PoE+).
⑦ Audio Out	Balanced or unbalanced stereo line level audio output.
⑧ RS232	Connect to the RS-232 controllable device.
⑧ IR	Connect to a modulated IR signal for IR communication with remote controlled device.
⑨ Video Out	Connect a USB cable to PC for video capture out.
⑩ HDMI Out	Connect an HDMI display for local monitoring.
⑪ HDMI in	Connect HDMI cable from this port to video source.
⑫ PC	Connect USB cable from this port to PC. Note: If you use HDMI cable for video source input, we recommend you connect PC port at the same time for system working properly.
⑬⑭ Device	Connect to USB device. Note: This connector is supplying 500mA to connected USB device.
⑮ Power	Connect to power adapter (12V/2A).

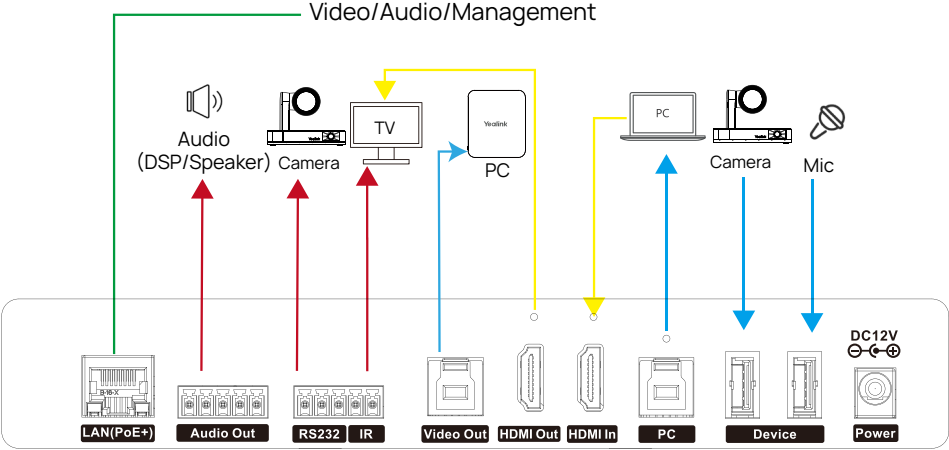
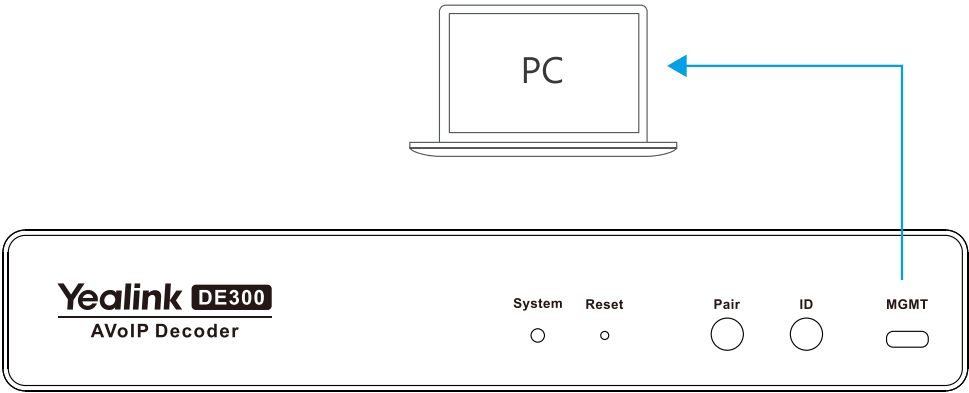

- USB Cable
- Network Cable
- HDMI
- IR/RS232/Audio Out

# LED Indicator Instructions

## • System Light

LED Status	Description
Off	Powered off.
Solid green	In normal and operational status.
Solid orange	<ul style="list-style-type: none"><li>• Booting.</li><li>• Initializing.</li></ul>
Slowly flashing orange	Updating firmware.
Fast flashing orange twice	Resetting.
Flashing red twice	Change backup system.
Continuously flashing red	Network error.
Flashing red and green alternate	Searching devices.

## • Pair Light

LED Status	Description
Off	Not in pairing mode.
Slowly flashing green	In pairing mode.
Solid green	Device pairing successful.

# Connection

## Audio Out Connector

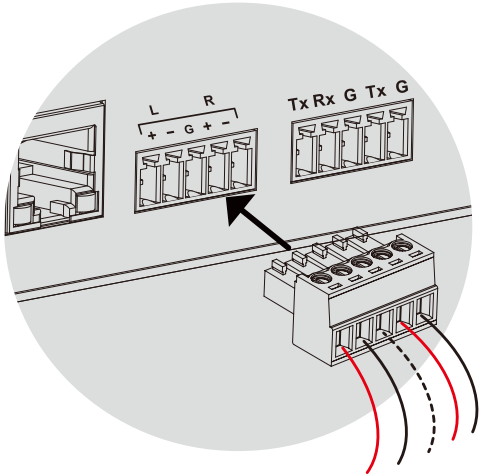

The lines are not included, please purchase separately.

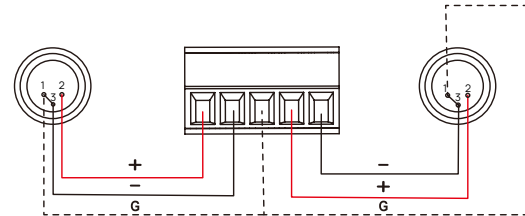
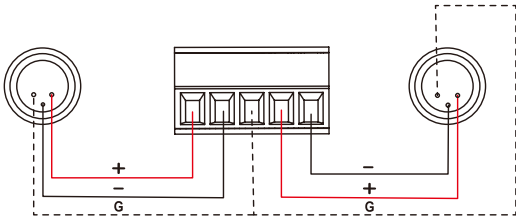
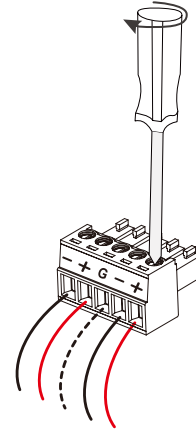

# RS-232/IR Connector

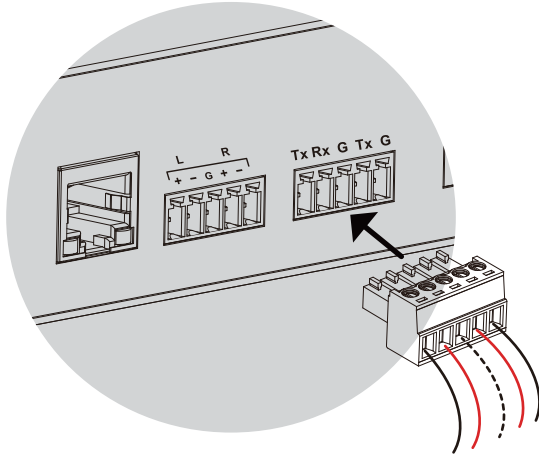

The lines are not included, please purchase separately.

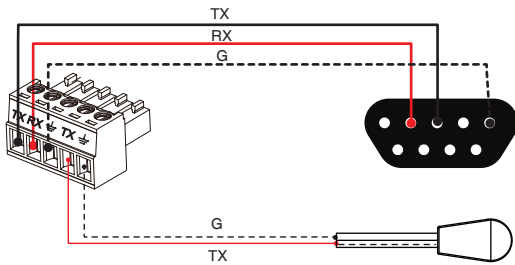
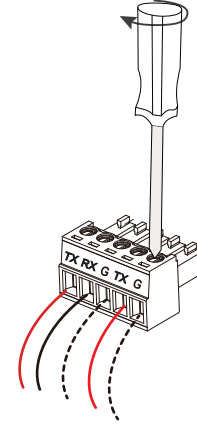

DB9 Male Connector

Infrared Emitter

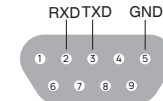

The wire connected to the infrared emitter's positive terminal is identified by light gray striped markings.

## How to Use Cable Locker

- 1 Insert the HDMI or USB cable into the corresponding port.
- 2 Use screws to secure the cable locker to the small hole above the port.
- 3 Use a zip tie to fasten the cable locker and cable together tightly.

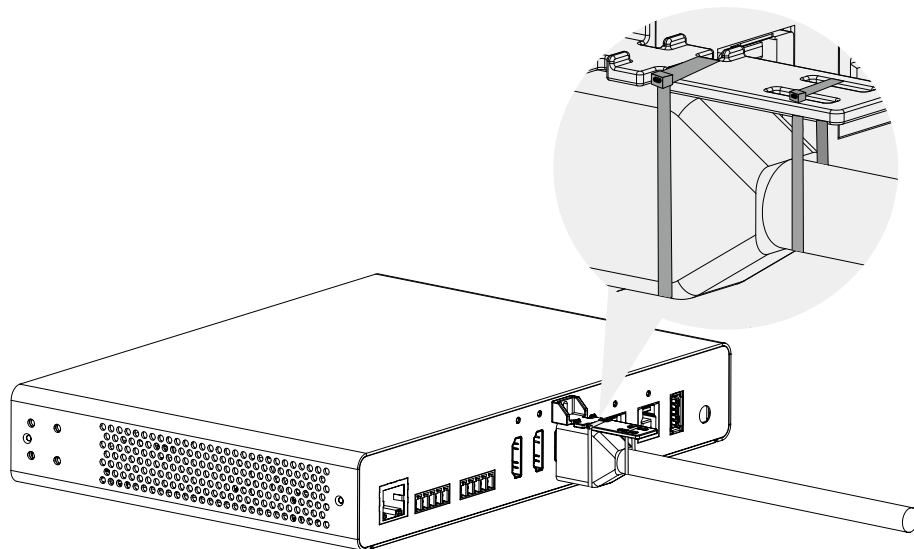

# Lieferumfang

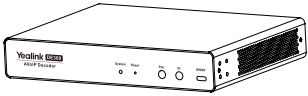

DE300

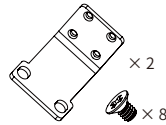

Montagebügel  
Schraube:

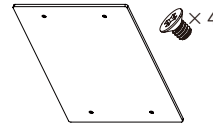

Verbindungsteil  
und Schrauben



Dübelmuttern und  
Schrauben



(12V, 2A)  
Netzteil



(1.8m, 5.9ft)  
HDMI Kabel

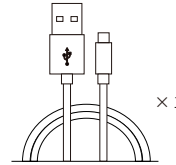

(1m, 3.28ft)  
USB-Kabel 3.0 Typ(A - C)

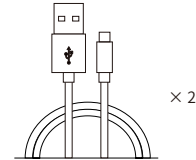

(2.5m, 8.2ft)  
USB 3.0 Typ (B-A) Kabel



Kabelverschluss



Infrarotsender

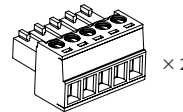

Männlicher Phoenix-  
Steckverbinder



Kurzanleitung

 Wir empfehlen Ihnen, das von Yalink bereitgestellte oder autorisierte Zubehör zu verwenden. Die Verwendung von nicht autorisiertem Zubehör von Drittanbietern kann zu einer schlechten Leistung führen.

- Methode 1: Auf dem Rack (19 Zoll) montieren
- Einzelgerät-Installation

**1** Installieren Sie die Montageohren auf einer Seite des Geräts.

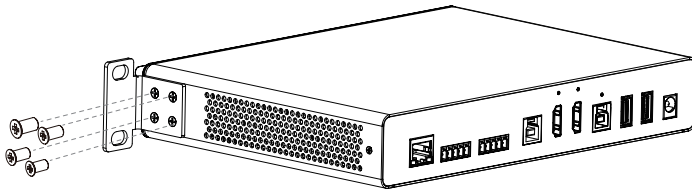

**2** Schieben Sie den DE300 in das Rack und befestigen Sie ihn dann mit Schrauben am Rack.

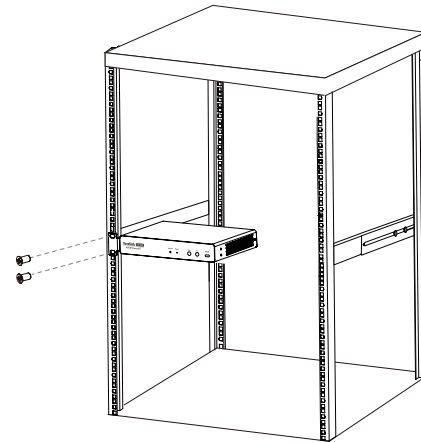

## • Duale Geräteinstallation

- 1 Verbinden Sie die beiden DE300 sicher mit Schrauben und Verbindungsteil.
- 2 Befestigen Sie die Montierungswinkel an beiden Seiten der beiden DE300.

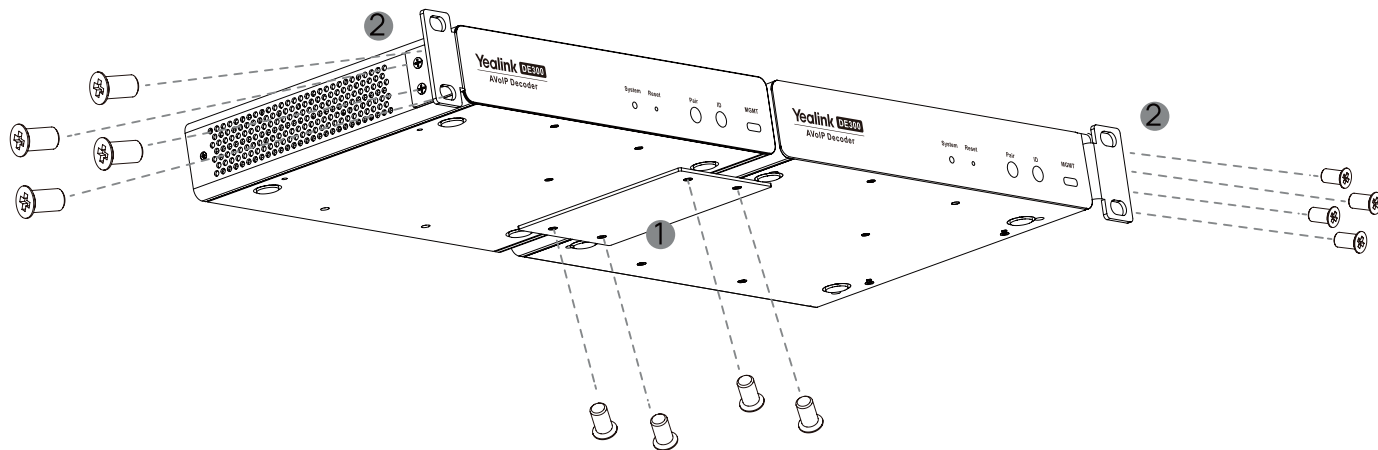

- 3 Schieben Sie den DE300 in das Rack und befestigen Sie ihn dann mit Schrauben am Rack.

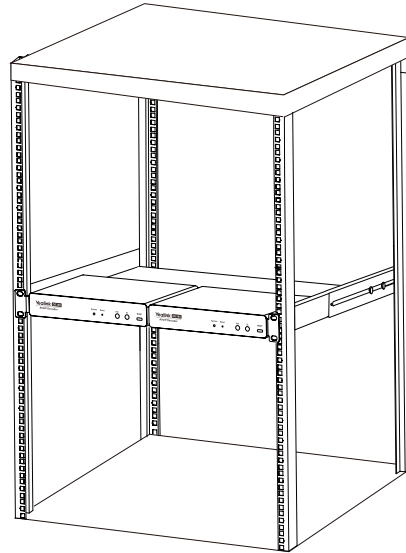

## • Methode 2: Unter einem Tisch oder an einer Wand (mit Montageohren)

- 1 Montieren Sie die Befestigungsöhren auf beiden Seiten des DE300.
- 2 Verwenden Sie die Montageohren, um Löcher auf der Montagefläche zu markieren.
- 3 Bohren Sie Löcher und setzen Sie die Expansionsmuttern ein.
- 4 Befestigen Sie den DE300 mit den Spreizschrauben auf der Montagefläche.

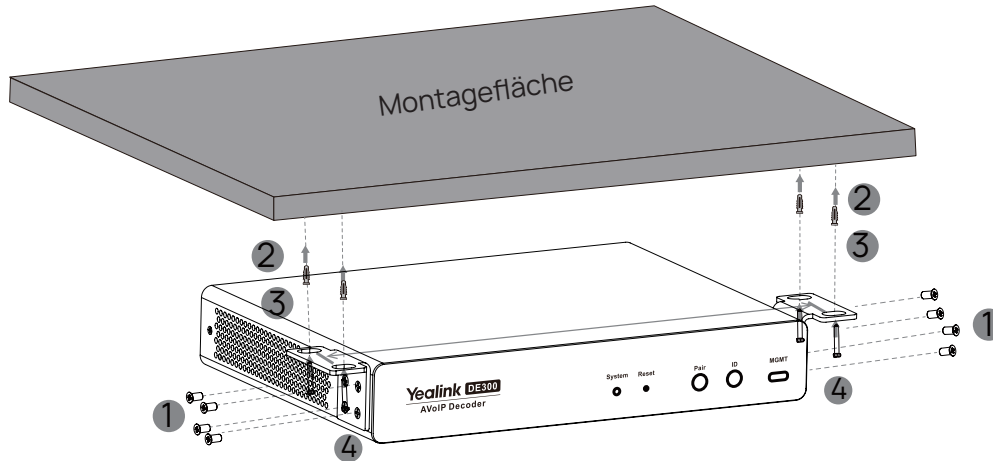

# Anleitung für die Hardware-Schnittstelle

## Frontplatte

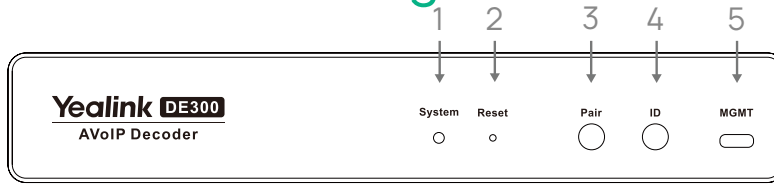

Interface	Beschreibung
① Systemlicht	Siehe Seite 23 für die Lichteffekte.
② Reset	<ul style="list-style-type: none"><li>• Nach dem Einschalten die Taste 5 Sekunden lang gedrückt halten, um DE300 auf die Werkseinstellungen zurückzusetzen.</li><li>• Schalten Sie das Gerät ein, indem Sie die Taste gedrückt halten, und halten Sie nach dem Einschalten die Taste 10 Sekunden lang gedrückt, um zum Backup-System zu wechseln.</li></ul>
③ Paar	Diese Schaltfläche bietet zwei Funktionen: <ul style="list-style-type: none"><li>• Drücken Sie die Taste 3 Sekunden lang, um zu koppeln.</li><li>• Drücken Sie die Taste 3 Sekunden lang, um das Pairing zu beenden.</li></ul> Siehe Seite 24 für die Lichteffekte.
④ ID	Diese Schaltfläche bietet zwei Funktionen: <ul style="list-style-type: none"><li>• Drücken Sie die Taste und lassen Sie sie los, um den Hostnamen und die IP-Adresse anzuzeigen.</li><li>• Drücken Sie die Taste 3 Sekunden lang, um die Erkennung in der Softwareoberfläche zu aktivieren.</li></ul>
⑤ MGMT	Verbinden Sie den Computer über diese Schnittstelle, um sich bei <a href="https://192.168.62.8">https://192.168.62.8</a> anzumelden und auf die Webschnittstelle des Geräts zur Verwaltung zuzugreifen. Der Standardbenutzername lautet admin.

## Rückplatte

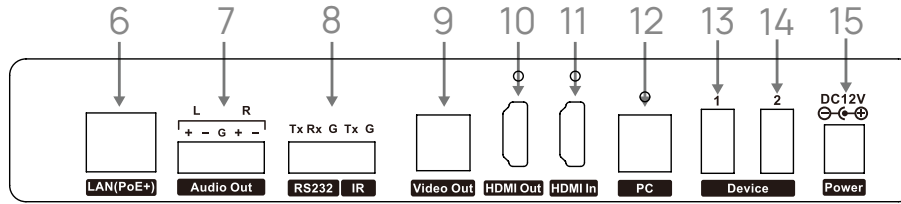

Interface	Beschreibung
⑥ LAN	RJ-45-Anschluss für Gerätesteuerung und -verwaltung (PoE+).
⑦ Audio-Ausgang	Ausgewogenes oder unausgewogenes Stereo-Line-Level-Audioausgang.
⑧ RS232	Verbinden Sie sich mit einem steuerbaren RS-232-Gerät.
⑧ IR	Verbinden Sie sich mit einem modulierten IR-Signal für die IR-Kommunikation mit einem fernbedienten Gerät.
⑨ Video-Ausgang	Schließen Sie ein USB-Kabel an den PC an, um das Video aufzunehmen.
⑩ HDMI-Ausgang	Schließen Sie ein HDMI-Display für die lokale Überwachung an.
⑪ HDMI Eingang	Schließen Sie das HDMI-Kabel von diesem Anschluss an die Videoquelle an.
⑫ PC	Schließen Sie das USB-Kabel von diesem Anschluss an den PC an. Hinweis: Wenn Sie ein HDMI-Kabel für den Videoquelleneingang verwenden, empfehlen wir Ihnen, den PC-Anschluss gleichzeitig zu verbinden, damit das System ordnungsgemäß funktioniert.

⑬⑭ Gerät	Mit USB-Gerät verbinden. Hinweis: Dieser Anschluss versorgt das angeschlossene USB-Gerät mit 500mA.
⑮ Stromversorgung	Mit Netzadapter (12V/2A) verbinden.

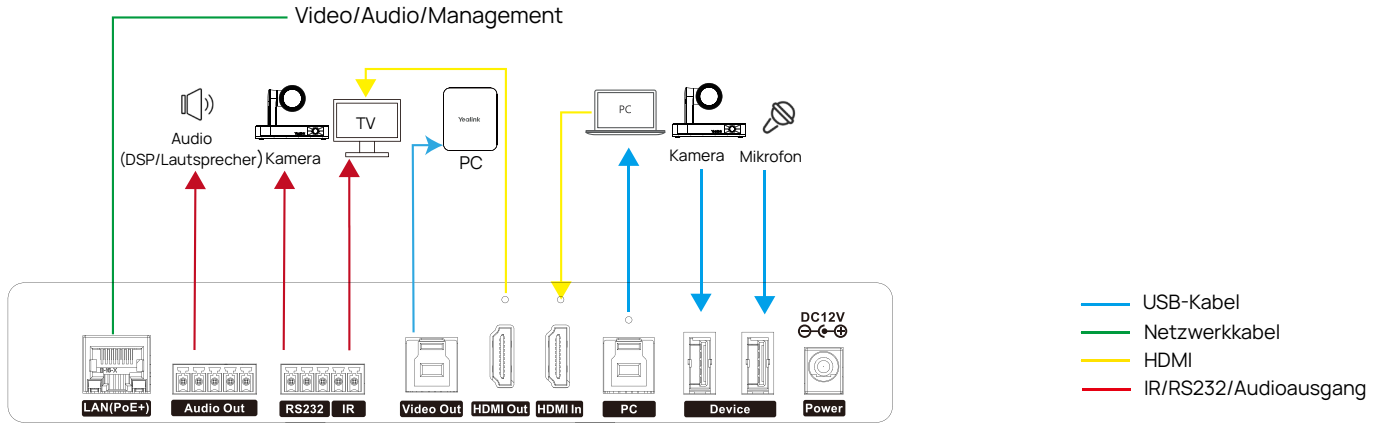
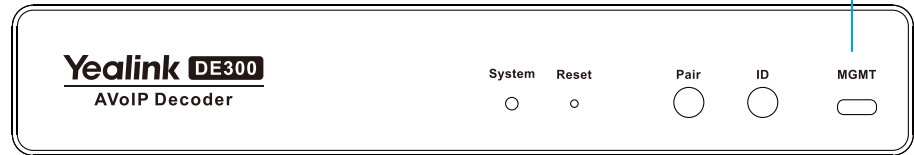

# LED-Anzeigen - Anweisungen

## • Systemlicht

LED-Status	Beschreibung
Aus	Stromversorgung aus
Dauerhaft grün	Im normalen und betrieblichen Zustand.
Dauerhaft orange	<ul style="list-style-type: none"><li>• Hochfahren</li><li>• Initialisierung</li></ul>
BlinktlangsamOrange	Firmware aktualisieren
Schnelles orangefarbenes Blinken zweimal	Zurücksetzen.
Zweimal rot blinkend	Backup-System ändern.
Kontinuierlich blinkend rot	Netzwerkfehler.
Blinkt abwechselnd rot und grün	Suche nach Geräten

- Paar Licht

LED-Status	Beschreibung
Aus	Nicht im Pairing-Modus.
Blinkt langsam grün	Im Pairing-Modus.
Dauerhaft grün	Geräte-Paarung erfolgreich.

# Verbindung

## Audiowiedergabeanschluss

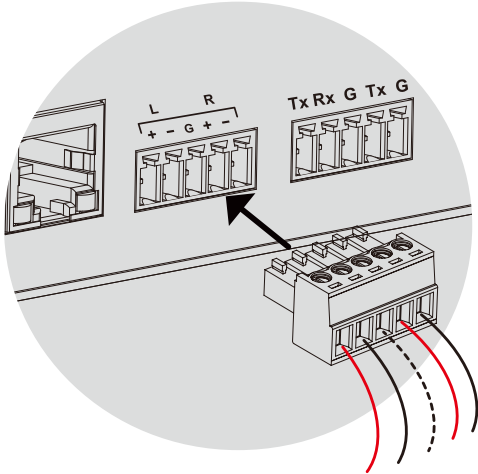

Die Leitungen sind nicht enthalten, bitte separat kaufen.

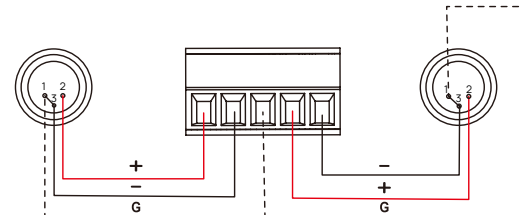
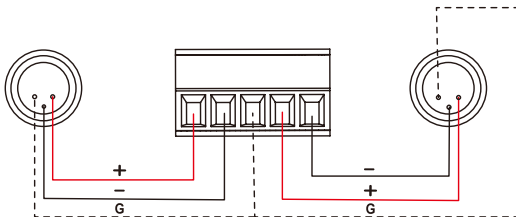
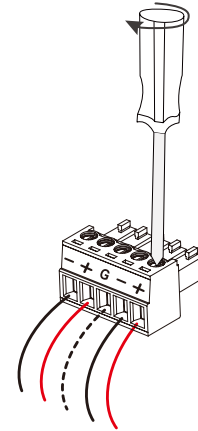

# RS-232 / IR Anschluss

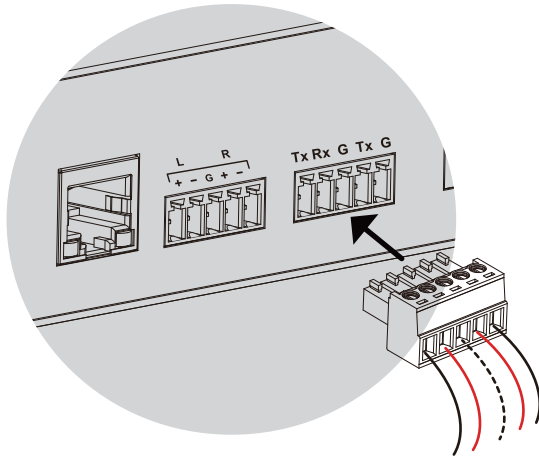

Die Leitungen sind nicht enthalten, bitte separat kaufen.

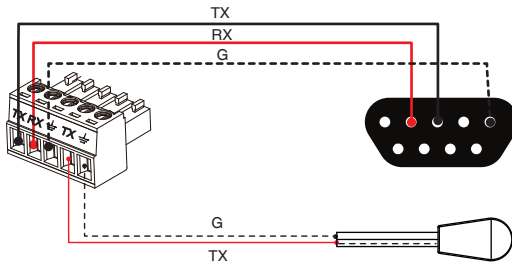
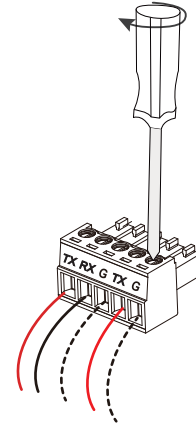

DB-Stecker

Infrarot-Emitter

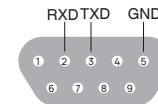

Der Draht, der mit dem positiven Anschluss des Infrarot-Emitters verbunden ist, ist durch hellgraue gestreifte Markierungen gekennzeichnet.

## Wie man einen Kabelschloss verwendet

- 1 Stecken Sie das HDMI- oder USB-Kabel in den entsprechenden Anschluss.
- 2 Verwenden Sie Schrauben, um den Kabelschloss an dem kleinen Loch über dem Anschluss zu befestigen.
- 3 Verwenden Sie einen Kabelbinder, um den Kabelschloss und das Kabel fest zusammenzuhalten.

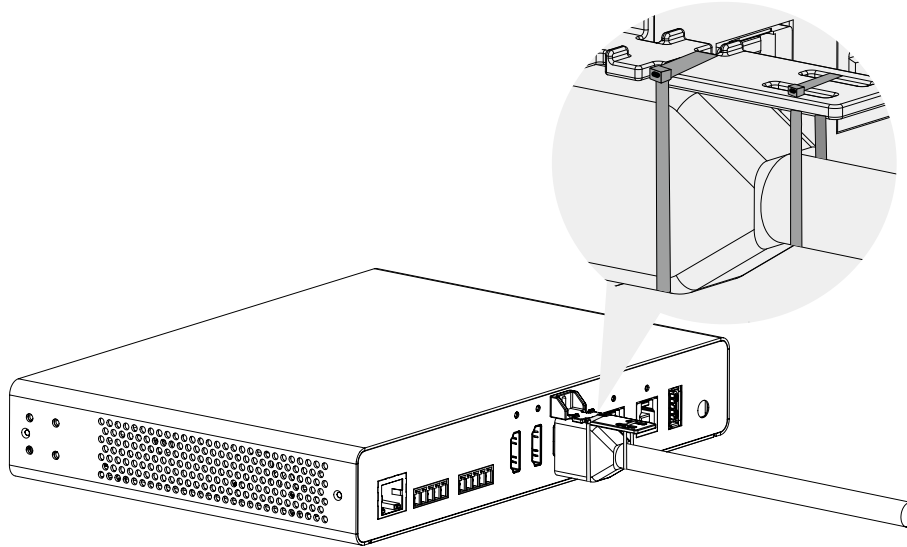

# Contenu de la boîte

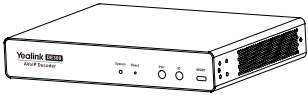

DE300

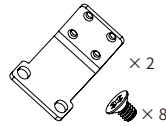

Équerres de fixation  
Vis

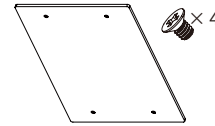

Pièce de connexion  
et Vis



Écrous  
d'expansion et vis



(12 V/2 A)  
Adaptateur  
secteur



(1,8m, 5,9ft)  
Câble HDMI

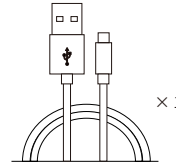

(1m, 3,28ft)  
Câble USB 3.0 Type (A-  
C)

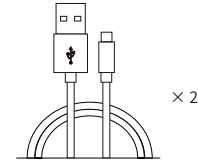

(2,5m, 8,2ft)  
Câble USB 3.0 de type B à A



Casier à câbles



Emetteur infrarouge

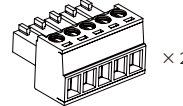

Connecteur Phoenix mâle



Guide de démarrage rapide

 Nous vous conseillons d'utiliser les accessoires fournis ou approuvés par Yealink. Les accessoires tiers non approuvés peuvent entraîner de moins bonnes performances.

## Méthode 1 Monter sur le rack (19 pouces)

- Installation d'un seul appareil

**1** Installez les oreilles de montage sur un côté de l'appareil.

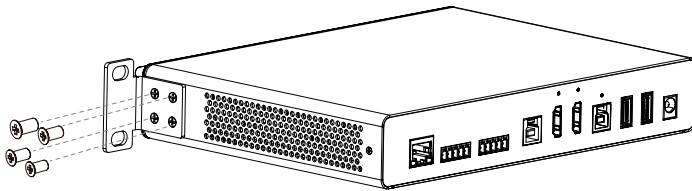

**2** Poussez le DE300 dans le rack, puis fixez-le au rack avec des vis.

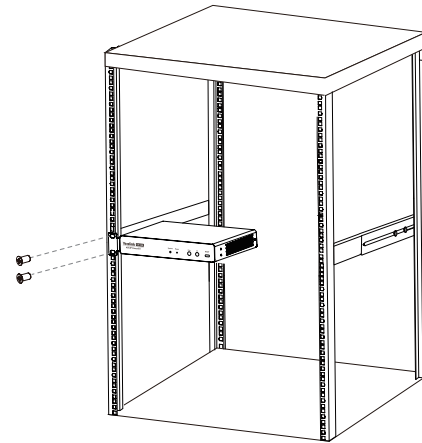

## • Installation de dispositifs doubles

- 1 Connectez solidement les deux DE300 à l'aide de vis et de la pièce de connexion.
- 2 Fixez les oreilles de montage des deux côtés gauche et droit des deux appareils DE300.

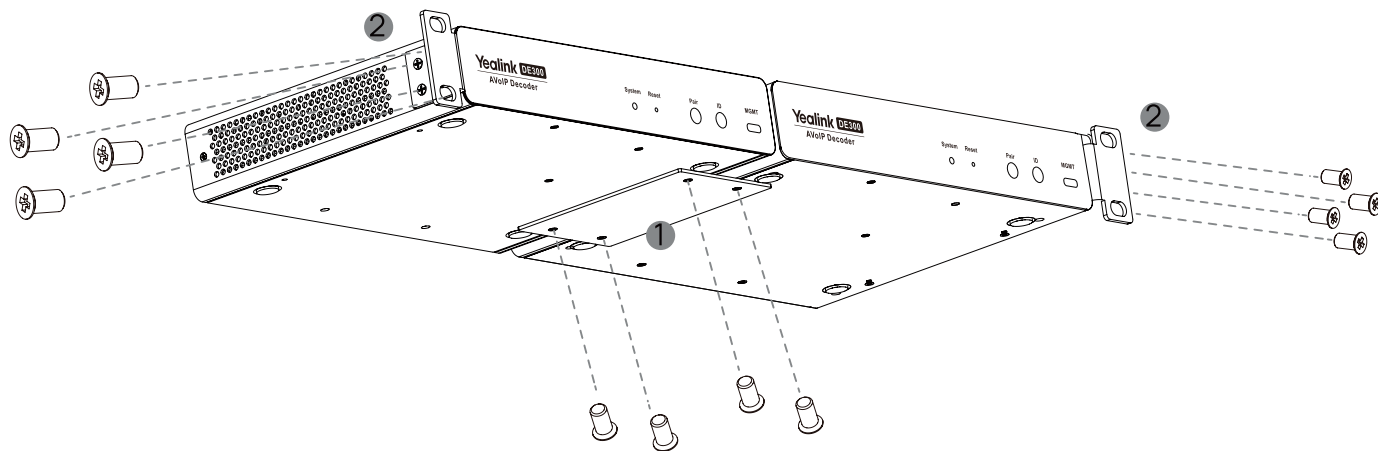

- 3 Poussez le DE300 dans le rack, puis fixez-le au rack avec des vis.

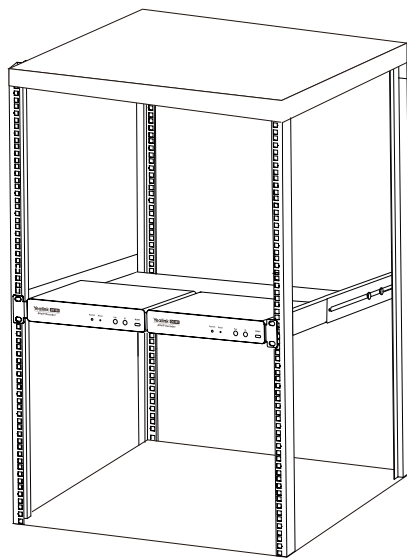

## • Méthode 2: Sous une table ou sur un mur (à l'aide des oreilles de montage)

- 1 Installez les oreilles de montage des deux côtés du DE300.
- 2 Utilisez les oreilles de montage pour marquer les trous sur la surface de montage.
- 3 Percez des trous et insérez les écrous d'expansion.
- 4 Fixez le DE300 sur la surface de montage avec les vis d'expansion.

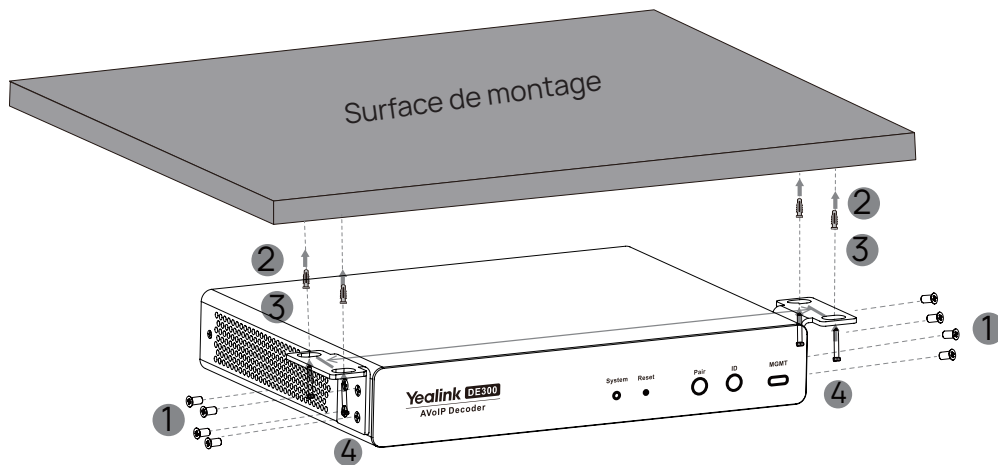

# Instructions de l'interface matérielle

## Panneau avant

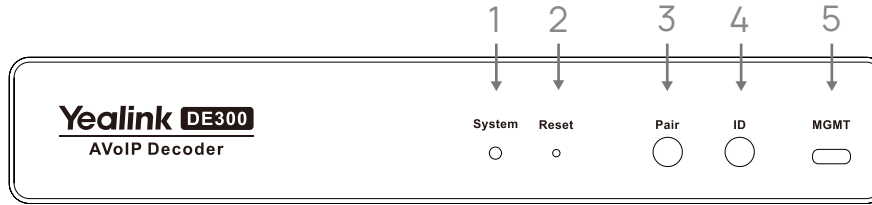

Interface	Description
① Système Voyant	Voir la page 37 pour les effets d'éclairage.
② Réinitialiser	<ul style="list-style-type: none"><li>Après avoir mis sous tension, maintenez le bouton enfoncé pendant 5 secondes pour réinitialiser le DE300 aux paramètres d'usine.</li><li>Allumez l'appareil en maintenant le bouton enfoncé, et après l'allumage, maintenez le bouton enfoncé pendant 10 secondes pour passer au système de secours.</li></ul>
③ Paire	Ce bouton offre deux fonctions : <ul style="list-style-type: none"><li>Appuyez sur le bouton pendant 3 s pour appairer.</li><li>Appuyez sur le bouton pendant 3 secondes pour terminer l'appairage.</li></ul> Voir la page 38 pour les effets d'éclairage.
④ ID	Ce bouton offre deux fonctions : <ul style="list-style-type: none"><li>Appuyez et relâchez le bouton pour afficher le nom d'hôte et l'adresse IP.</li><li>Appuyez sur le bouton pendant 3 secondes pour activer la reconnaissance dans l'interface du logiciel.</li></ul>
⑤ MGMT	Connectez l'ordinateur via cette interface pour vous connecter à <a href="https://192.168.62.8">https://192.168.62.8</a> afin d'accéder à l'interface web de l'appareil pour la gestion. Le nom d'utilisateur par défaut est admin.

## Panneau arrière

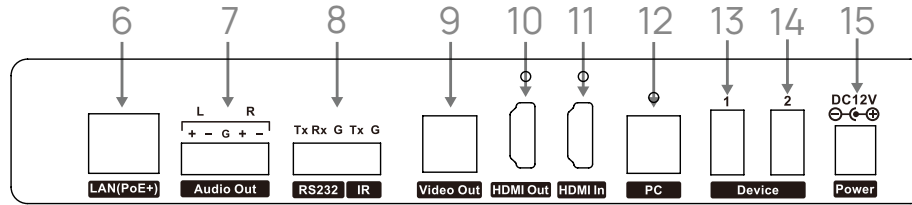

Interface	Description
⑥ LAN	Port RJ-45 pour le contrôle et la gestion des appareils (PoE+).
⑦ Sortie audio	Sortie audio de niveau ligne stéréo équilibrée ou non équilibrée.
⑧ RS232	Connectez-vous à un appareil contrôlable RS-232.
⑧ IR	Connectez-vous à un signal IR modulé pour la communication IR avec un appareil télécommandé.
⑨ Sortie Vidéo	Connectez un câble USB à l'ordinateur pour la capture vidéo.
⑩ Sortie HDMI	Connectez un écran HDMI pour la surveillance locale.
⑪ HDMI entrée	Connectez le câble HDMI de ce port à la source vidéo.
⑫ Un ordinateur :	Connectez le câble USB de ce port au PC. Remarque: Si vous utilisez un câble HDMI pour l'entrée de source vidéo, nous vous recommandons de connecter le port PC en même temps pour que le système fonctionne correctement.

⑬⑭ Dispositif	Connectez-vous à l'appareil USB. Remarque : Ce connecteur fournit 500 mA à l'appareil USB connecté.
⑮ Puissance	Connectez-vous à l'adaptateur secteur (12V/2A).

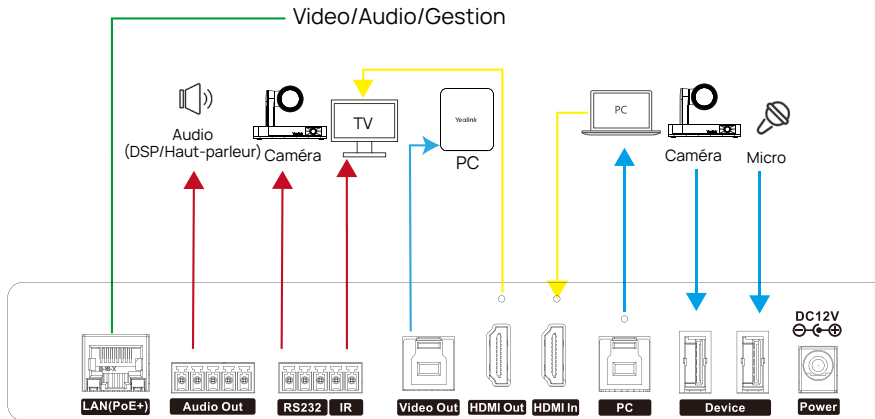
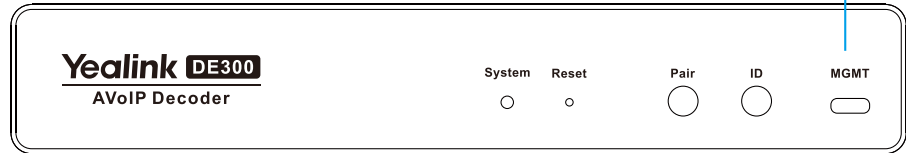

# Instructions du voyant LED

## • Système Voyant

État des LED	Description
Désactivé	Éteint
Vert fixe	En état normal et opérationnel.
Orange fixe	<ul style="list-style-type: none"><li>• Démarrage</li><li>• Initialisation</li></ul>
Orange clignotant lentement	Mise à jour du firmware
Clignotement rapide orange deux fois	Réinitialiser
Clignotant rouge deux fois	Changer le système de sauvegarde.
Clignotement rouge continu	Erreur réseau.
Clignote rouge et vert alternativement	Recherche de périphériques

- Appairer la lumière

État des LED	Description
Désactivé	Pas en mode appairage.
Vert clignotant lentement	En mode de couplage.
Vert fixe	Appairage de l'appareil réussi.

# Connexion

## Connecteur audio de sortie

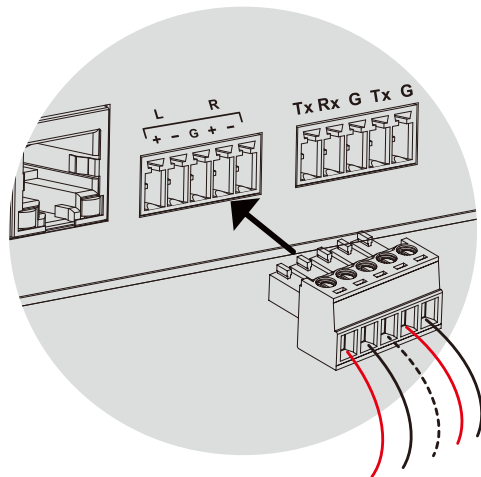

Les lignes ne sont pas incluses, veuillez les acheter séparément.

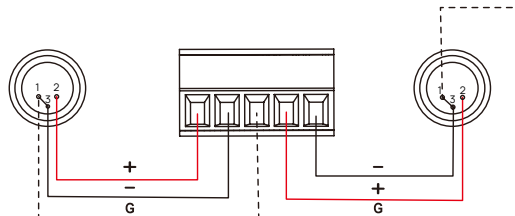
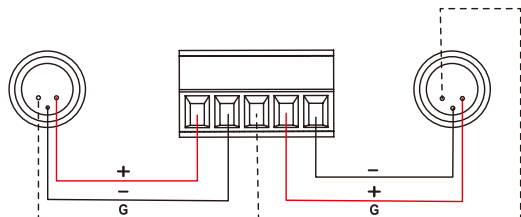
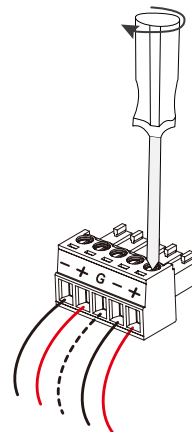

## Connecteur RS-232/IR

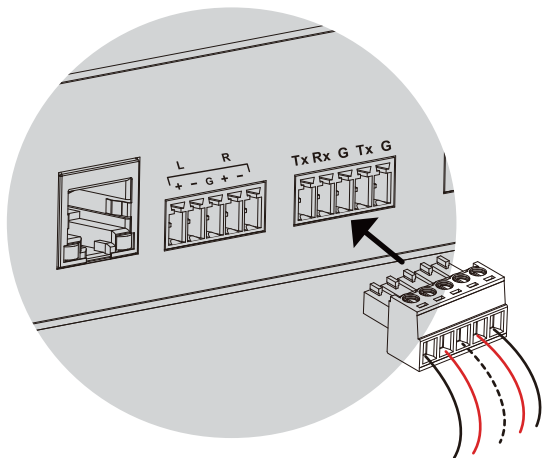

 Les lignes ne sont pas incluses, veuillez les acheter séparément.

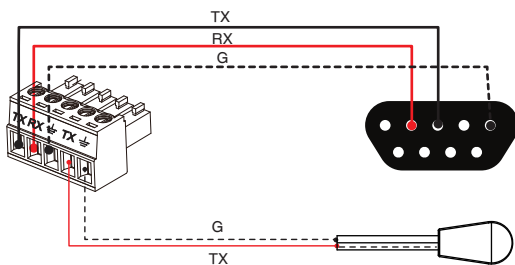
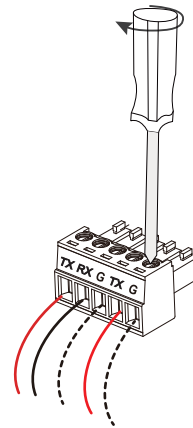

Connecteur mâle DB

Emetteur infrarouge

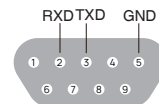

 Le fil connecté à la borne positive de l'émetteur infrarouge est identifié par des marquages à rayures gris clair.

## Comment utiliser un verrou de câble

- 1 Insérez le câble HDMI ou USB dans le port correspondant.
- 2 Utilisez des vis pour fixer le coffre à câbles au petit trou au-dessus du port.
- 3 Utilisez un lien en plastique pour attacher le coffre de câble et le câble ensemble de manière serrée.

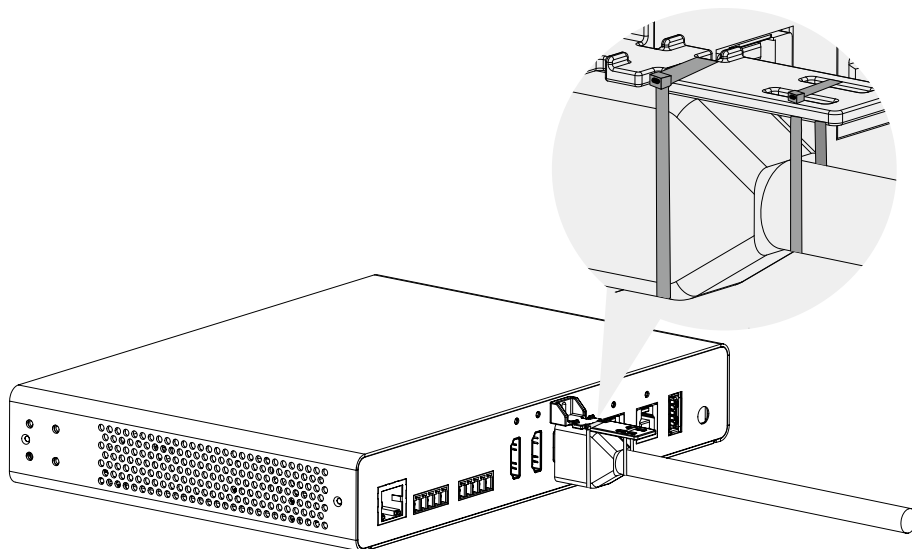

# Contenido de la caja

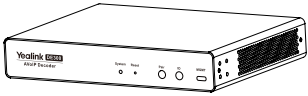

DE300

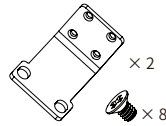

Montaje de Orejas y Tornillo

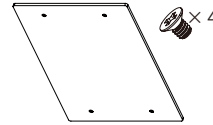

Pieza de Conexión y tornillos



Tuercas y tornillos de expansión



(12V/2A)  
Adaptador de corriente

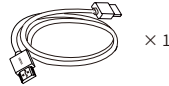

(1.8m, 5.9ft)  
Cable HDMI

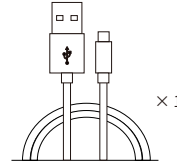

(1m, 3.28ft)  
Cable USB 3.0 (A - C)

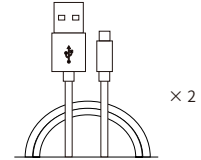

(2.5m, 8.2ft)  
Cable USB 3.0 (B - A)



Cerradura de cable



emisor infrarrojo

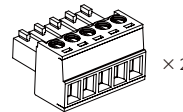

Conector Phoenix Masculino



Guía de inicio rápido

 Utilice siempre accesorios proporcionados o aprobados por Yealink. El uso de accesorios de terceros no aprobados puede afectar al funcionamiento.

- Método 1: Montaje en el Rack (19 pulgadas)
- Instalación en un solo dispositivo

**1** Instale las orejas de montaje en un lado del dispositivo.

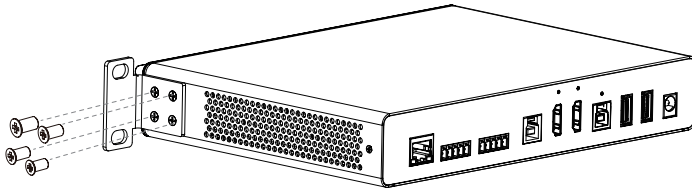

**2** Empuje el DE300 en el rack y luego fíjelo al rack con tornillos.

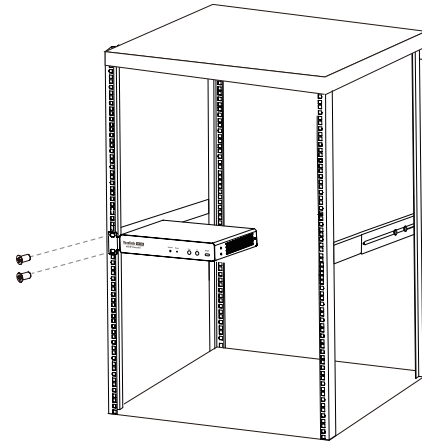

## • Instalación de Dispositivos Duales

- 1 Conecte de forma segura los dos dispositivos DE300 utilizando tornillos y pieza de conexión.
- 2 Adjunte las orejas de montaje a ambos lados izquierdo y derecho de los dos dispositivos DE300

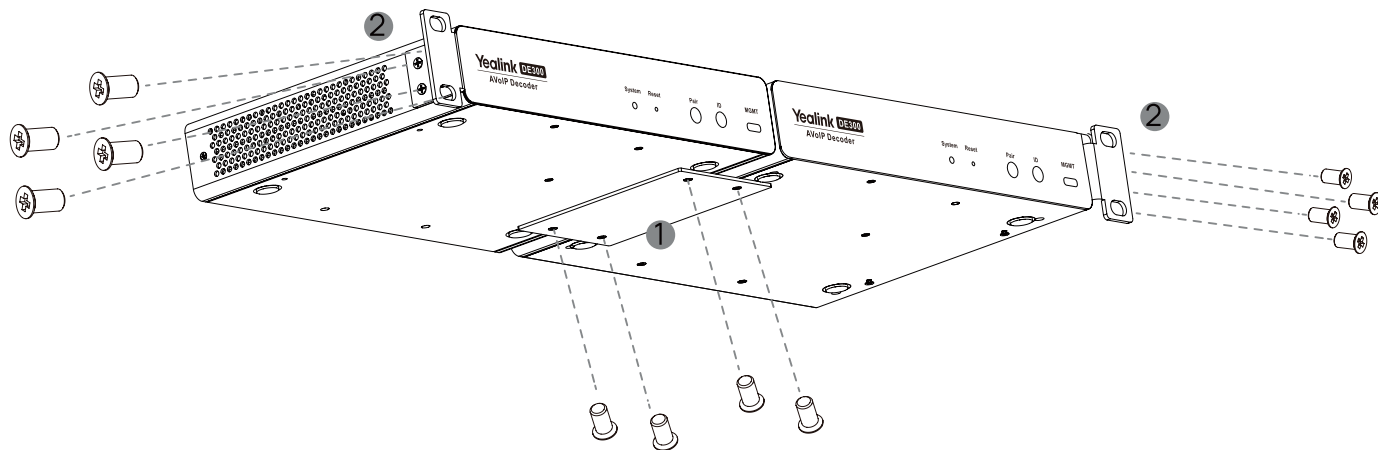

- 3 Empuje el DE300 en el rack y luego fíjelo al rack con tornillos.

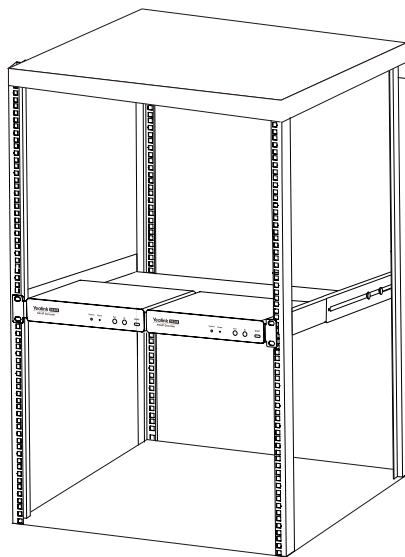

## • Método 2: Bajo una mesa o en una pared (Usando soportes de montaje)

- 1 Instale las orejetas de montaje a ambos lados del DE300.
- 2 Utiliza las orejas de montaje para marcar los agujeros en la superficie de montaje.
- 3 Perfore agujeros e inserte las tuercas de expansión.
- 4 Fije el DE300 en la superficie de montaje con los tornillos de expansión.

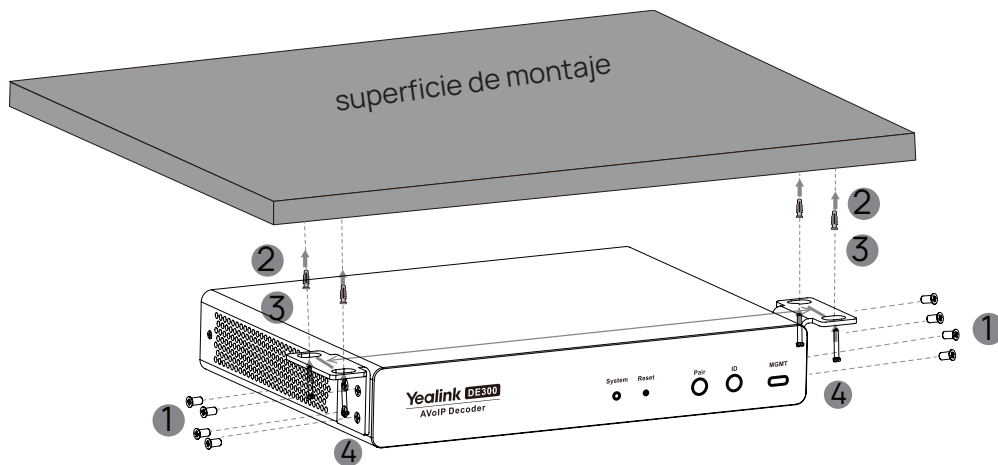

# Instrucciones de Interfase de hardware

## Panel Frontal

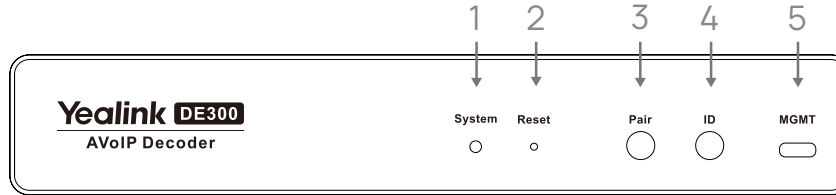

Interfase	Descripción
① Luz del sistema	Consulta la página 50 para los efectos de iluminación.
② Reset	<ul style="list-style-type: none"><li>• Después de encender, mantenga presionado el botón durante 5 segundos para restablecer el DE300 a los valores de fábrica.</li><li>• Encienda el dispositivo manteniendo presionado el botón, y después de encenderlo, mantenga presionado el botón durante 10 s para cambiar al sistema de respaldo.</li></ul>
③ Par	Este botón proporciona dos funciones: <ul style="list-style-type: none"><li>• Presiona el botón durante 3 s para emparejar.</li><li>• Presiona el botón durante 3 s para terminar el emparejamiento.</li></ul> Consulta la página 50 para los efectos de iluminación.
④ ID	Este botón proporciona dos funciones: <ul style="list-style-type: none"><li>• Presione y suelte el botón para mostrar el nombre del host y la dirección IP.</li><li>• Presiona el botón durante 3 s para habilitar el reconocimiento en la interfaz del software.</li></ul>
⑤ MGMT	Conecta el ordenador a través de esta interfaz para iniciar sesión en <a href="https://192.168.62.8">https://192.168.62.8</a> y acceder a la interfaz web del dispositivo para su gestión. El nombre de usuario predeterminado es "admin".

## Panel trasero

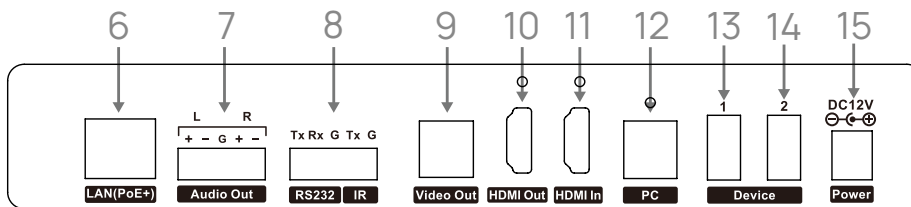

Interfase	Descripción
⑥ LAN	Puerto RJ-45 para control y gestión del dispositivo (PoE+).
⑦ Salida de audio	Salida de audio de nivel de línea estéreo balanceada o no balanceada.
⑧ RS232	Conectar a un dispositivo controlable por RS-232.
⑧ IR	Conéctate a una señal IR modulada para la comunicación IR con un dispositivo controlado a distancia.
⑨ Salida de video	Conecta un cable USB a la PC para la salida de captura de video.
⑩ Salida HDMI	Conecta una pantalla HDMI para monitoreo local.
⑪ HDMI de entrada	Conecte el cable HDMI desde este puerto a la fuente de video.
⑫ PC	Conecta el cable USB desde este puerto al PC. Nota: Si utiliza un cable HDMI para la entrada de fuente de video, le recomendamos que conecte el puerto del PC al mismo tiempo para que el sistema funcione correctamente.
⑬⑭ Dispositivo	Conectar al dispositivo USB. Nota: Este conector está suministrando 500mA al dispositivo USB conectado.
⑮ energía	Conéctate al adaptador de corriente (12V/2A).

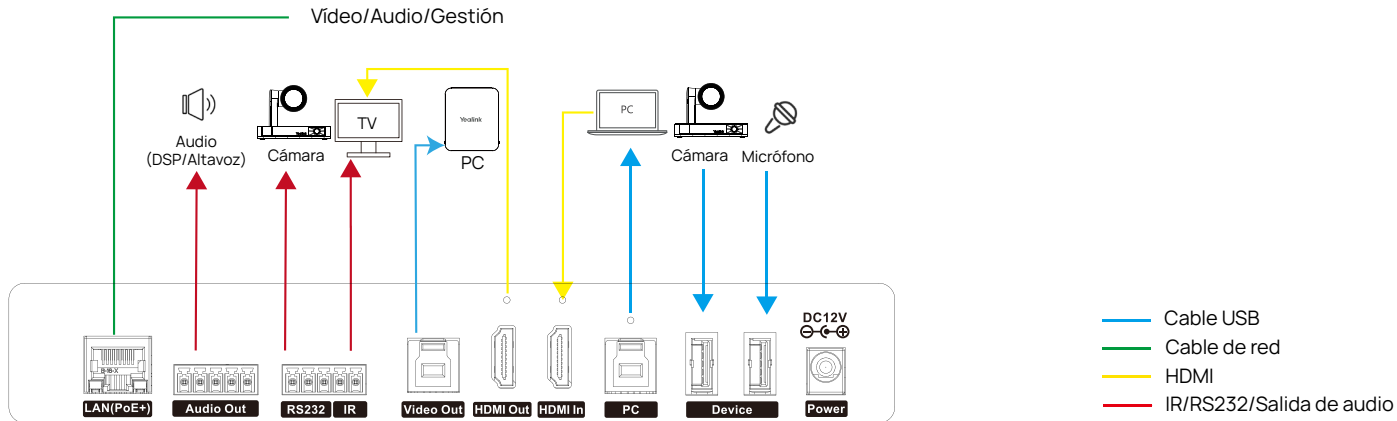
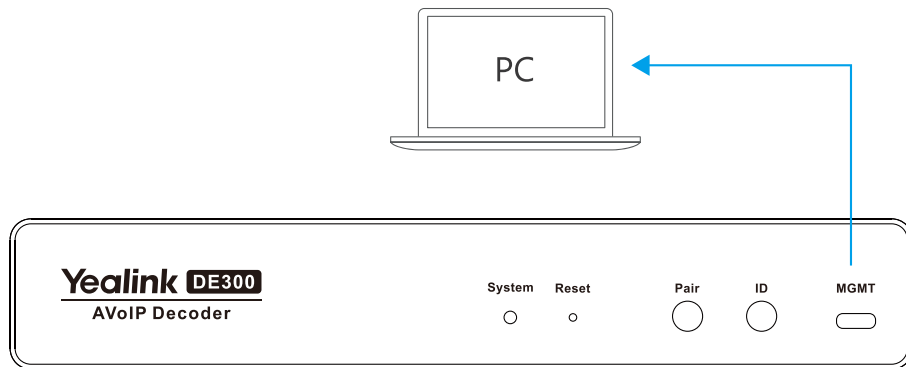

# Estado del indicador LED

## • Luz del sistema

Estado de LED	Descripción
Apagado	Apagado
Verde fijo	En estado normal y operativo.
Naranja sólido	<ul style="list-style-type: none"><li>• Arrancando</li><li>• Inicializando.</li></ul>
parpadeando lentamente en naranja	Actualizando el firmware.
Parpadeo rápido naranja dos veces	Reiniciando.
Destello rojo dos veces	Cambiar el sistema de respaldo.
Parpadeando rojo continuamente	Error de red.
Destellos rojos y verdes alternos	Buscando dispositivos.

## • Emparejar Luz

Estado de LED	Descripción
Apagado	No en modo de emparejamiento.
Verde intermitente lento	En modo de emparejamiento.
Verde fijo	Emparejamiento de dispositivo exitoso.

# Conexión

## Conector de salida de audio

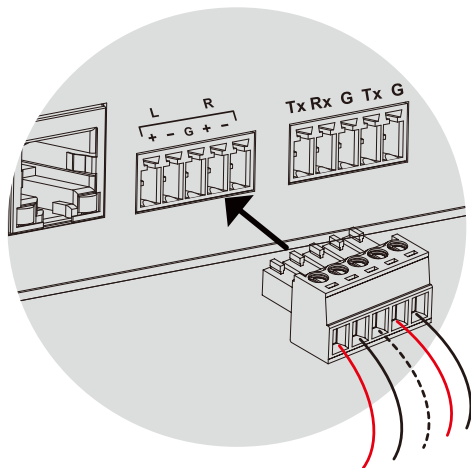

Las líneas no están incluidas, por favor cómprelas por separado.

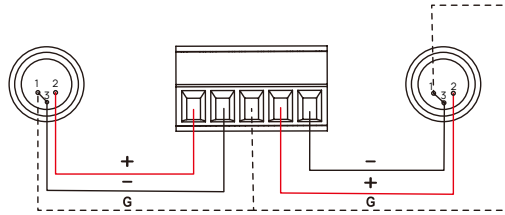
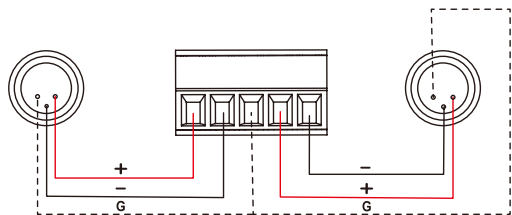
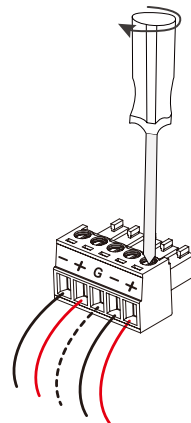

## Conector RS-232/IR

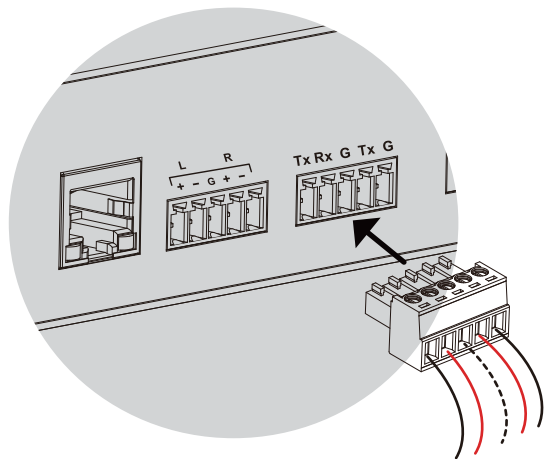

**i** Las líneas no están incluidas, por favor cómprelas por separado.

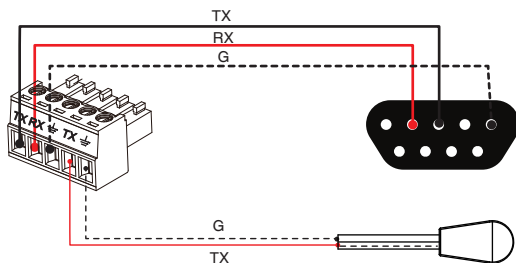
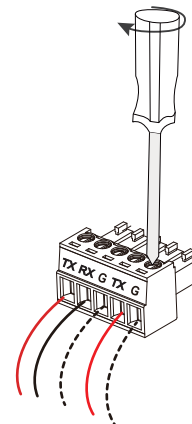

Conector macho DB

Emisor de infrarrojos

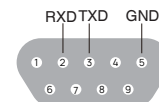

**i** El cable conectado al terminal positivo del emisor infrarrojo está identificado por marcas de rayas gris claro.

## Cómo usar un candado para cables

- 1 Inserte el cable HDMI o USB en el puerto correspondiente.
- 2 Utiliza tornillos para asegurar el candado de cables al pequeño agujero encima del puerto.
- 3 Usa una brida para sujetar el candado del cable y el cable juntos firmemente.

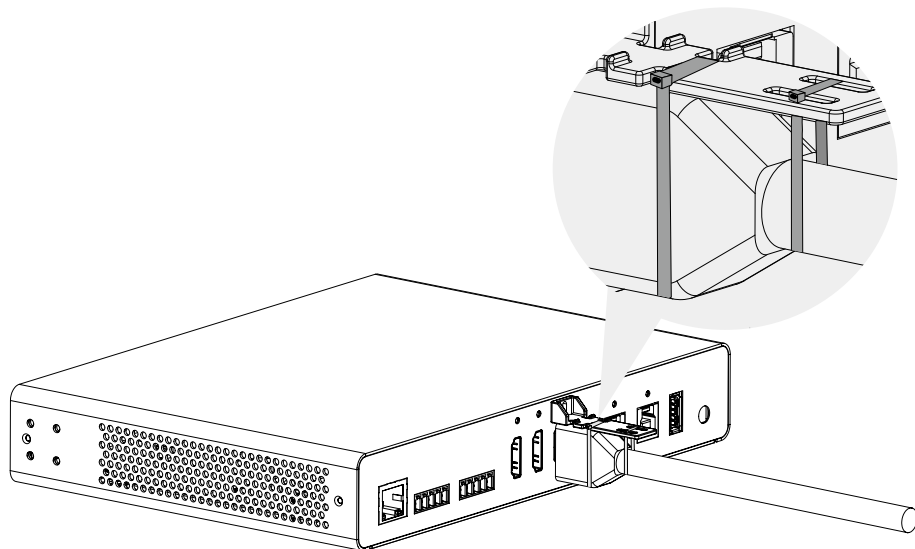

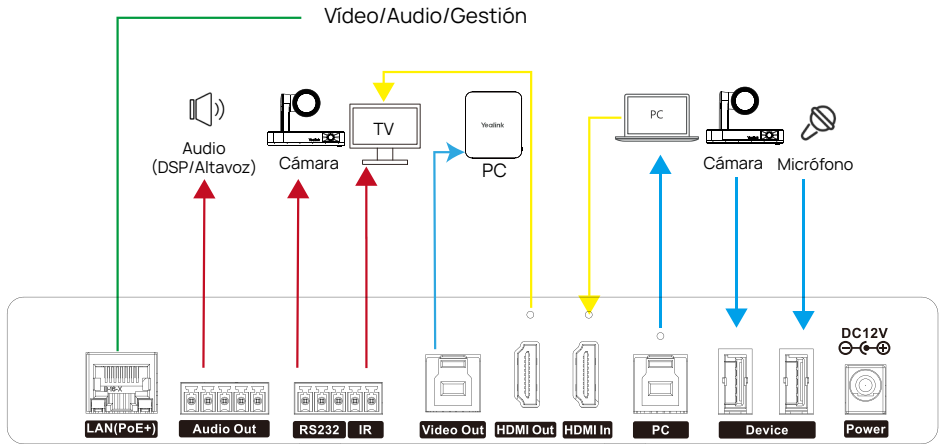
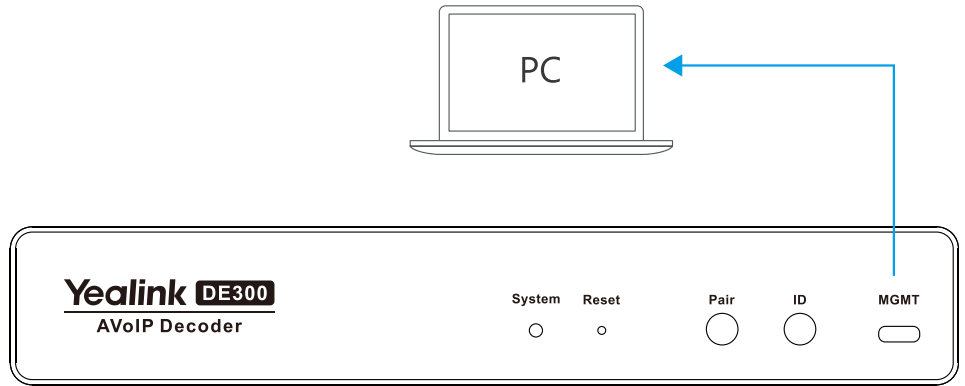

- Cable USB
- Cable de red
- HDMI
- IR/RS232/Salida de audio



## Declaration of Conformity

We,

YEALINK(XIAMEN) NETWORK TECHNOLOGY CO.,LTD

Address: No.666 Hu'an Rd. Huli District Xiamen City, Fujian, P.R. China

Manufacturer: YEALINK(XIAMEN) NETWORK TECHNOLOGY CO.,LTD

Address: No.666 Hu'an Rd. Huli District Xiamen City, Fujian, P.R. China

DATE: 25<sup>th</sup> / April / 2025

declare that the product

Type: AVoIP Decoder

Model: DE300

meets the essential requirements and other relevant provisions according to the following EC directive

Directive: 2014/30/EU, 2014/35/EU

### Conformity

The product complies with the following standards:

Safety: EN 62368-1:2020+A11:2020

EMC: EN 55032:2015+A11:2020

EN 55035:2017+A11:2020

EN IEC 61000-3-2: 2019+A1:2021

EN 61000-3-3: 2013+A1:2019

Harmonized:EN62321-1-2013

Directive 2011/65/EU and (EU)2015/863 of the European Parliament and of the Council of 8 June 2011 and 4 June 2015 on the restriction of the use of certain hazardous substances in electrical and electronic equipment(RoHS 2.0)

Directive 2012/19/EU of the European Parliament and of the Council of 4.July.2012 on Waste electrical and electronic equipment(WEEE)

Regulation (EC) No.1907/2006 of the European Parliament and of the Council of 18.December.2006 on Registration, Evaluation, Authorization, and Restriction of Chemicals (REACH)

The declaration of conformity is issued under the sole responsibility of the manufacturer

NAME: Huahu Wang

DATE:

TITLE: Manager

*Huahu Wang*  
25 / Apr / 2025

## About Yealink

Yealink (Stock Code: 300628) is a global-leading provider of Unified Communication & Collaboration Solutions specialized in video conferencing, voice communications, and collaboration, dedicated to helping every person and organization embrace the power of "Easy Collaboration, High Productivity".

With best-in-class quality, innovative technology, and user-friendly experiences, Yealink is one of the best providers in more than 140 countries and regions, ranks No.1 in the global market share of IP Phone, and is the Top 5 leader in the video conferencing market (Frost & Sullivan, 2021).

## Technical Support

Visit Yealink WIKI (<http://support.yealink.com/>) for firmware downloads, product documents, FAQ, and more. For better service, we sincerely recommend you to use Yealink Ticketing system (<https://ticket.yealink.com>) to submit all your technical issues.

YEALINK NETWORK TECHNOLOGY CO.,LTD.  
No.666 Hu'an Rd,Huli District Xiamen City, Fujian, P.R. China  
[support@yealink.com](mailto:support@yealink.com)

Made in China

Yealink (Europe) Network Technology GmbH  
Georg-Muche-Straße 5, 80807 Munich  
[EUROPE@Yealink.com](mailto:EUROPE@Yealink.com)

YEALINK (USA) NETWORK TECHNOLOGY CO., LTD.  
Suite 160, 5445 legacy drive, Plano, Texas, 75024, United States  
Made in China

Copyright©2025 Yealink Inc. All right reserved.

